

# CANAPEA NOVILI

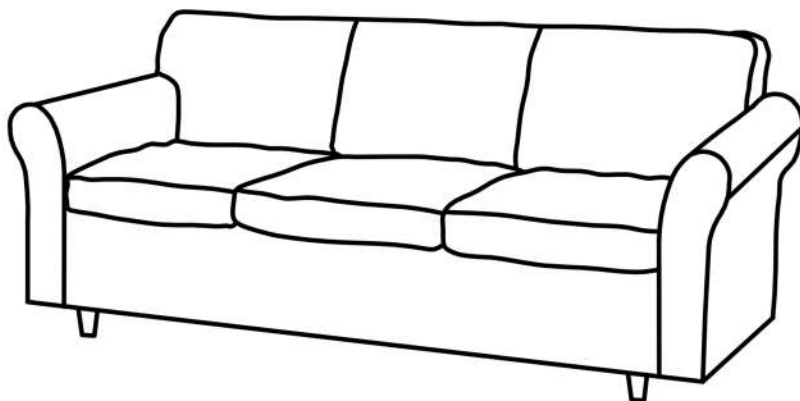

**Video de montaj**  
in pagina produsului  
pe [www.mobilalaguna.ro](http://www.mobilalaguna.ro)

## PASUL 1

Se ridica spatarul conform sagetii, apoi se ridica structura formand litera "L" vazuta din lateral cat sa aveti acces sub canapea (ca in figura)

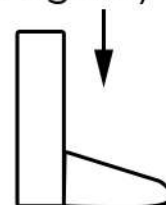
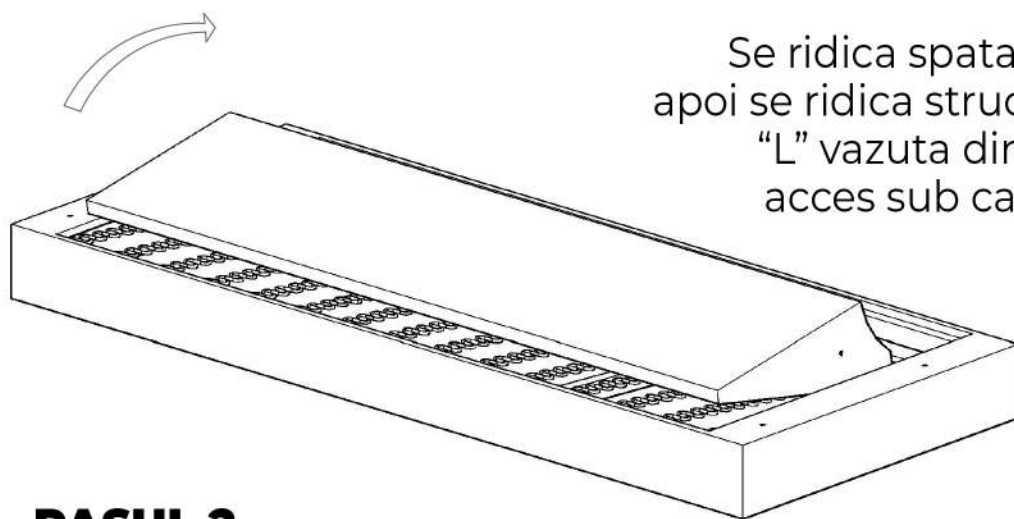

## PASUL 2

Se insurubeaza cate o piesa in zona laterala interna a fiecarui brat. Se pozitioneaza bratele pe structura. Atentie! Zonele de prindere pe laterala interna sa fie pozitionate in dreptul spatarului conform schitei

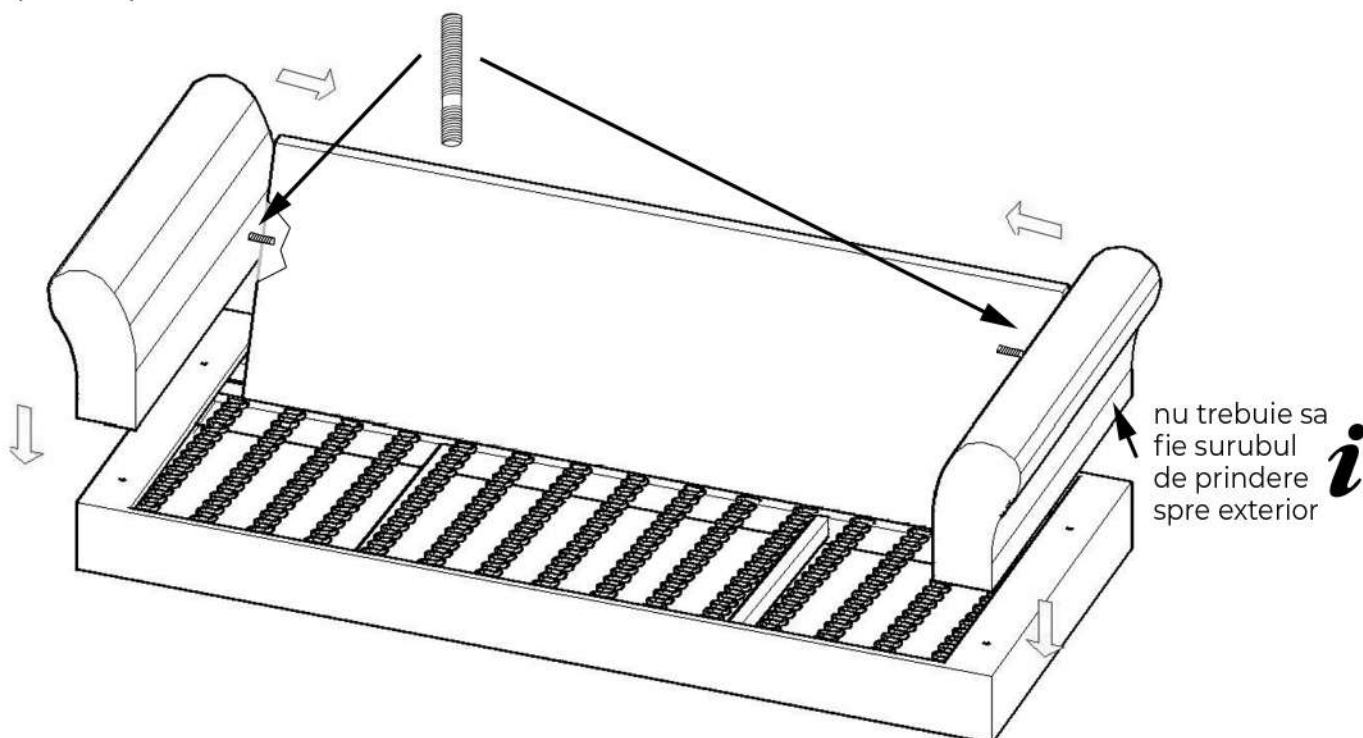

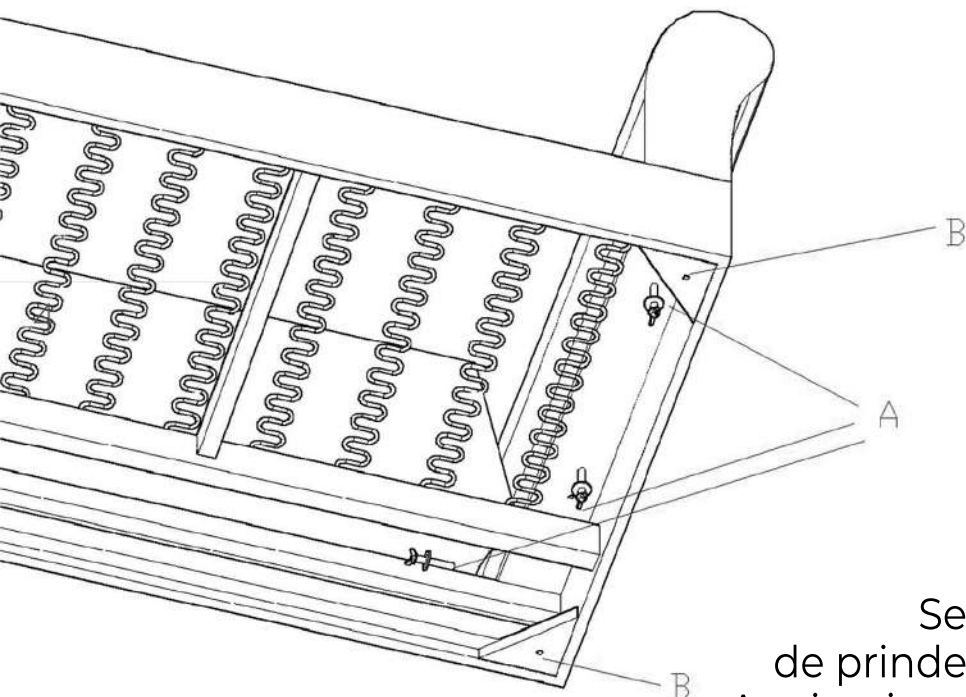

A 6X



B 4X

### PASUL 3

Se insurubeaza in cele 6 zone de prindere (A), cate 3 la fiecare brat. Apoi se insurubeaza cele 4 picioare (B). Se ridica in pozitia normala.

H 1X

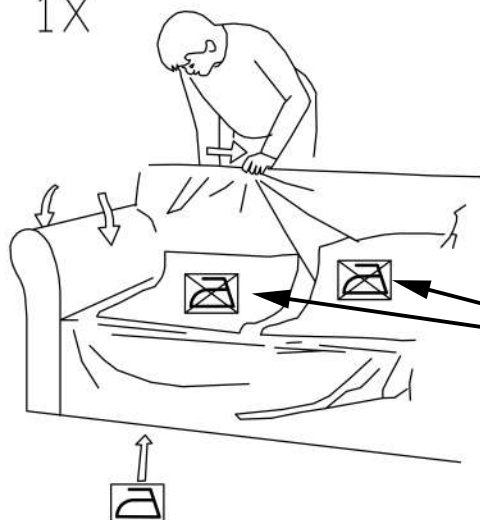

### PASUL 4

Se aplica husa canapelei. Optional recomandam calcarea in prealabil. Atentie zonele marcate pe schita nu se calca! Continuatii cu cele 3 perne pentru spatrar cat si 3 de sezut. Cele de sezut sunt mai ferme iar cele de spatrar mai moi.

P 3X

S 3X

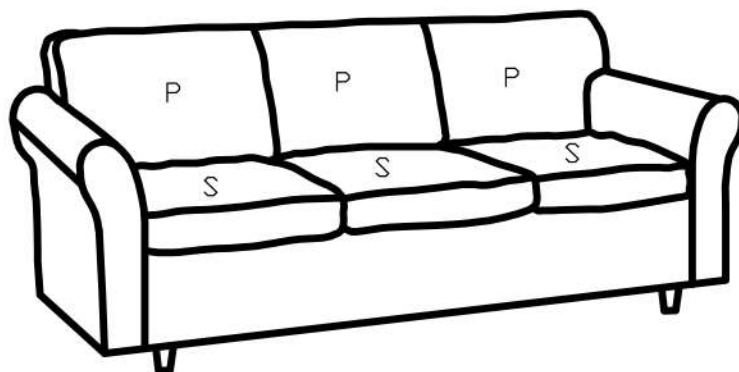
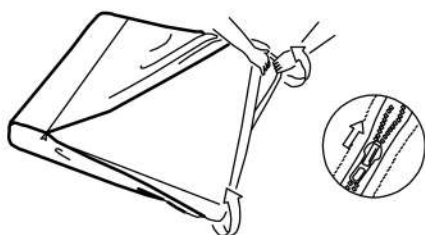

### CANAPEA NOVILI

Producator: SC Laguna Serv SRL  
Tel: 0731 343 271 / 0727 897 511